

APPLICATION NOTE

ANP032 | High Power Wireless Power Transfer for the Industrial Environment



Andreas Nadler, Cem Som

1. INTRODUCTION

As the presence of wireless power transfer technology increases in consumer electronics, the industrial and medical industries are shifting focus towards this technology and its inherent advantages. As communication interfaces are becoming increasingly wireless with technologies like WLAN and Bluetooth, wireless power transfer has become a relevant option. Completely new approaches can be taken that not only offer obvious technical advantages, but also open up possibilities for new industrial design. This technology offers new concepts - especially in industrial sectors struggling with tough environmental conditions, aggressive cleaning agents, heavy soiling and high mechanical stresses (e.g. ATEX, medicine, construction machines). For instance, expensive and susceptible slip rings or contacts can be substituted. Another field of application is with transformers, which have to satisfy special requirements, such as reinforced or doubled insulation.

The target of this Application Note is to demonstrate that easy-to-achieve solutions for wireless power transfer of one hundred Watts or more are reachable using circuit technology, without the need of software or controllers.

2. ZVS OSCILLATOR (DIFFERENTIAL MODE RESONANT CONVERTER)

A classical resonant converter is used as the clocking circuit in this Application Note.

This oscillator offers multiple benefits

- It oscillates independently and only requires a DC source
- The current and voltage profile is almost sinusoidal
- No active components and no software are needed
- It is scalable from 1 W – 200 W
- The MOSFETs switch close to the zero crossover point
- It is scalable for many different voltages/currents



Figure 1: Wireless power coils from Würth Elektronik.

APPLICATION NOTE

ANP032 | High Power Wireless Power Transfer for the Industrial Environment

2.1 Basic Circuit / Schematic

The basic circuit shown in Figure 2 is the transmitter side incl. transmitter coil LP. The receiver side can be constructed with the same basic circuit (see chapter 3.1).

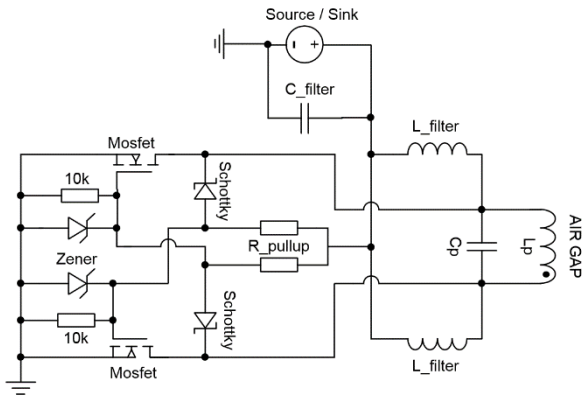

Figure 2: Basic resonant converter circuit.

2.2 Functionality

The resonant converter usually operates at a constant working frequency, which is determined by the resonant frequency of the LC parallel resonant circuit. As soon as a DC voltage is applied to the circuit, it starts to oscillate based on the MOSFETs component tolerances. Within a fraction of a second, one of the two MOSFETs is slightly more conductive than the other. The positive feedback of the two MOSFET gates and the opposite drain of the less conductive MOSFET gives rise to a 180° phase shift. The two MOSFETs are therefore always driven out of phase and can never conduct simultaneously. The MOSFETs alternately connect both ends of the parallel resonant circuit to ground allowing the resonant circuit to be periodically recharged with energy.

Inductive reactance (inductor):

$$X_L = 2 \cdot \pi \cdot f \cdot L \quad (1)$$

Capacitive reactance (capacitor):

$$X_C = \frac{1}{2 \cdot \pi \cdot f \cdot C} \quad (2)$$

Resonant frequency of ideal resonant circuit:

$$f_0 = \frac{1}{2 \cdot \pi \cdot \sqrt{L \cdot C}} \quad (3)$$

Impedance of parallel circuit:

$$Z_P = \frac{-jX_L \cdot X_C}{X_L - X_C} \quad (4)$$

Real Resonant frequency without coupling factor:

$$f_r = \frac{1}{2 \cdot \pi} \sqrt{\frac{1}{L \cdot C} - \frac{R_{DC}^2}{L^2}} = f_0 \sqrt{1 - \frac{R_{DC}}{Z_P}} \quad (5)$$

Another feature of this circuit topology is that the voltage always switches close to the zero crossover point, meaning the switching losses in the MOSFETs are very low. The disadvantage of this switching topology is that the power consumption in the idle state is relatively high due to the reactive currents circulating in the resonant circuit. For this reason, the resonant converter should ideally only be operated with a load. It should be considered that the frequency of the resonant circuit changes with the coupling factor of the receiver side. This arises due to the reflected impedance from the receiver side, which influences the magnetizing inductance of the transmitter side, as both sides are in parallel. A decreasing coupling factor causes the frequency to rise, as the magnetizing inductance of the transmitter side drops.

The basic circuit from Figure 1 can run with voltages from 3.3 V up to and above 230 V, depending on the components used. Above input voltages of 20 V, attention must be paid to touch protection, as the voltage in the resonant circuits already above the SELV (Safety Extra Low Voltage) threshold of 50 V_{AC} / 120 V_{DC} by a factor of π or more.

APPLICATION NOTE

ANP032 | High Power Wireless Power Transfer for the Industrial Environment

The efficiency of the entire wireless power transfer circuit may exceed 90% in practice. This is quite remarkable as the coupling losses via the air gap are already included and a steady DC voltage is available at the input. The efficiency remains stable within an air gap range of 4-10 mm. A large share of the energy in the magnetic field, which is not coupled to the receiver side, is returned to the "tank circuit". A maximum distance of up to 18 mm is possible depending on the application however, concessions are made in terms of coupling factor and EMC.

The circuit on the transmitter side can be used identically for the receiver side. The resonant converter then works as a synchronous rectifier. Here it needs to be considered that the resonant frequency of the receiver side should be very closely matched to that of the transmitter side. This also generates a maximum "absorption circuit effect". The parallel connection of C and L means that the secondary side behaves like a constant current source for the load. This allows the overall efficiency of the circuit to be raised significantly. In addition, the capacitor compensates the stray inductance of the wireless powercoil. If the circuit is prepared properly then the receiver can feed energy back to the transmitter (i.e. "Ideal" diode from Linear Technology at the load).



Figure 3: The voltages at the transmitter coil are shown in blue and red. The gate voltages are yellow and green (These measured voltage curves are referenced to the circuit ground GND; $V_{in} = 20\text{ V}$; $P_{out} = 100\text{ W}$; optimized gate drive, see application examples).

APPLICATION NOTE

ANP032 | High Power Wireless Power Transfer for the Industrial Environment

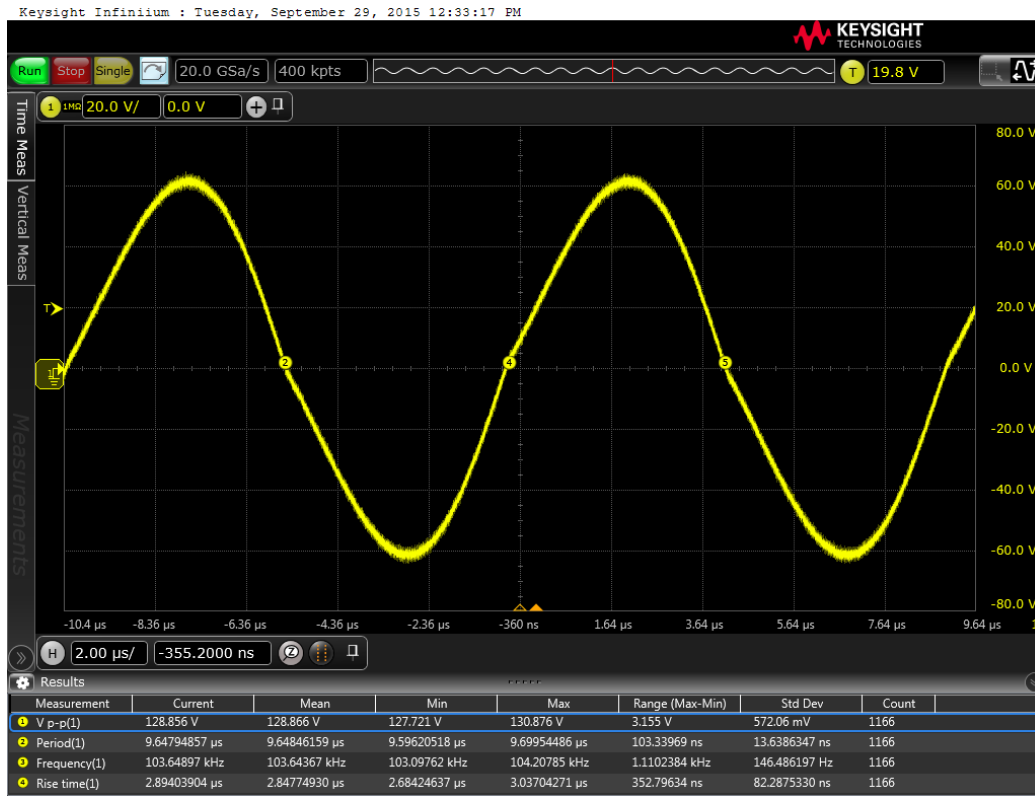

Figure 4: Voltage at the transmitter coil (not referenced to circuit GND; $V_{in} = 20\text{ V} / P_{out} = 100\text{ W}$).

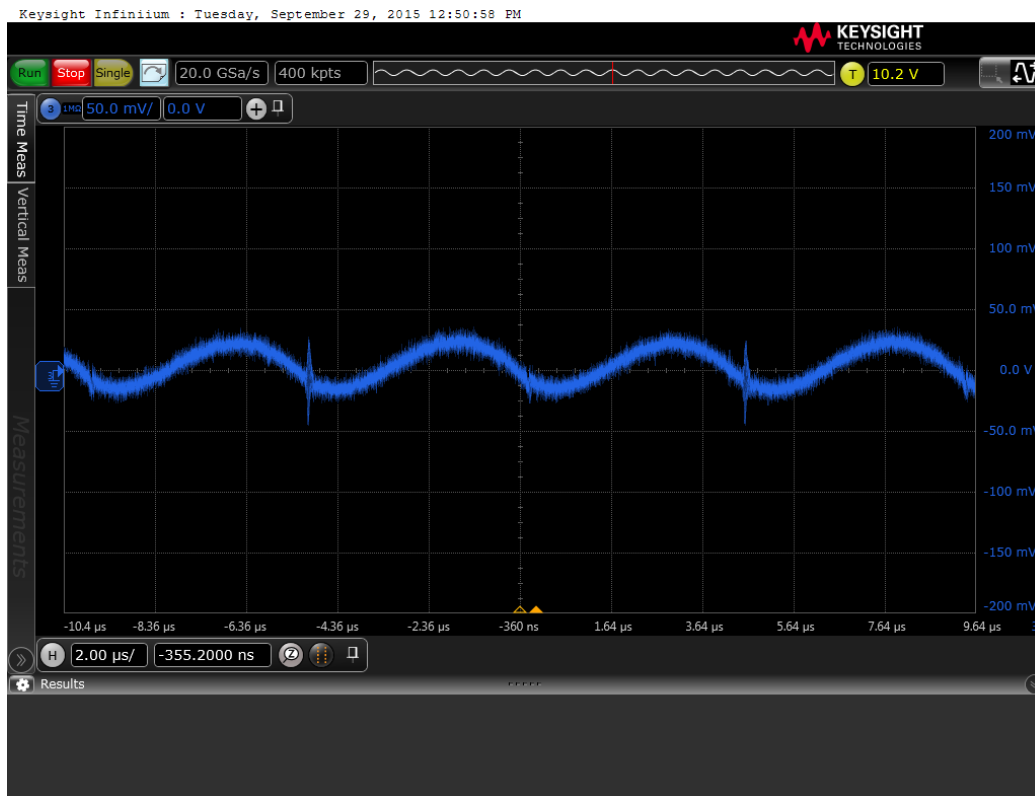

Figure 5: Reflected voltage ripple and noise to supply the input on the transmitter side ($V_{in} = 20\text{ V} / P_{out} = 100\text{ W}$) → Polymer and ceramic capacitors with a low ESR can be used to reduce the voltage ripple.

APPLICATION NOTE

ANP032 | High Power Wireless Power Transfer for the Industrial Environment

The efficiency can be raised by using smaller MOSFETs rather than Schottky diodes for driving the gate or by using a bipolar push-pull stage (see application examples in section 3).

For supply voltages over 20 V, a capacitive voltage divider can be used to drive the MOSFET gates or a DC/DC converter (like the highly efficient and compact [Würth Elektronik Magi³C Power Module](#)) as an auxiliary voltage source (see application examples in section 3).

Likewise, on the receiver side, instead of a resonant converter, a classical bridge rectifier can also be used. The advantage is a higher output voltage, lower costs and space savings at the cost of efficiency, due to diode losses.

The frequency under load should generally not exceed 150 kHz, otherwise the losses in the Parallel capacitors, transmitter and receivers coils become too high. Additionally, the EMC limit values are higher beneath 150 kHz (e.g. CISPR15 EN55015 9 kHz – 30 MHz). The frequency range 105 – 140 kHz emerged as the best compromise in tests carried out so far. This range also ensures that you remain in a safe range according to the currently approved frequency band for inductive power transfer (100 – 205 kHz).

If the end product will be launched in several countries, the regulations and permissible frequency bands should be ascertained for each country beforehand to speed up the development phase.

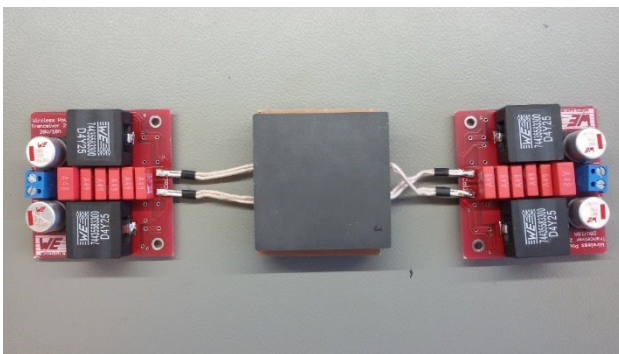

Figure 6: Measured circuit ($V_{in} = 20\text{ V}_{DC}$; $P_{out} = 100\text{ W}$) for a 6.5 mm air gap.



Figure 7: Measured circuit ($V_{in} = 20\text{ V}_{DC}$; $P_{out} = 100\text{ W}$) for a 6.5 mm air gap.

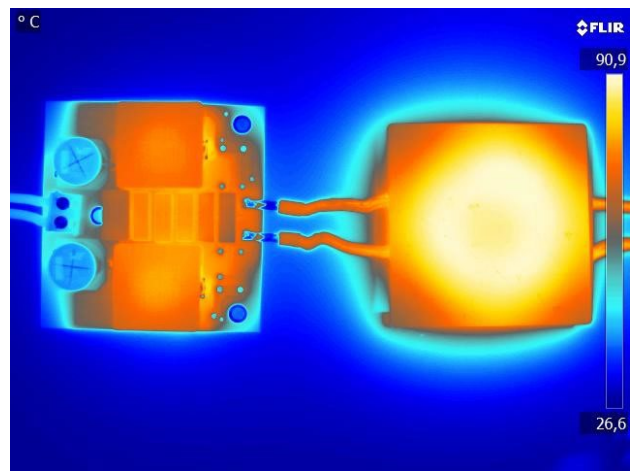

Figure 8: Temperature rise (upper side = filter + capacitors) of the circuit/coils for $P_{out} = 100\text{ W}$ ($V_{in} = 20\text{ V}$).

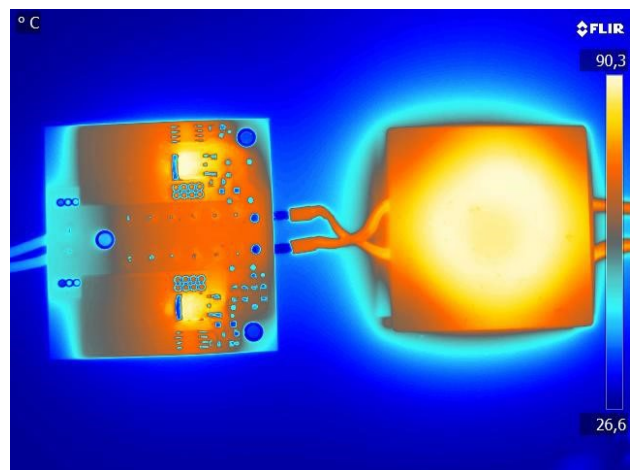

Figure 9: Temperature rise (lower side = MOSFETs + gate drive) of the circuit/coils for $P_{out} = 100\text{ W}$ ($V_{in} = 20\text{ V}$).

APPLICATION NOTE

ANP032 | High Power Wireless Power Transfer for the Industrial Environment

2.2.1 EMC Properties of Wireless Power Transformers

As power is transferred with all wireless power applications, compliance with the EMC limits are non-trivial. The challenge is that the transmitter and receiver coils behave like a transformer with a poor coupling factor and very large air gap. This leads to a very high stray electromagnetic field in the vicinity of the coils. EMC measurements have shown that

broadband interference can occur in the spectrum of the fundamental wave through to the frequency range of 80 MHz. If the level of interference measured is kept below the limit with a reserve, it may be assumed that the limits of the interference field strength are also maintained. Generally speaking, the limit from, e.g. EN55022 Class B, may represent a development challenge which is not to be underestimated.

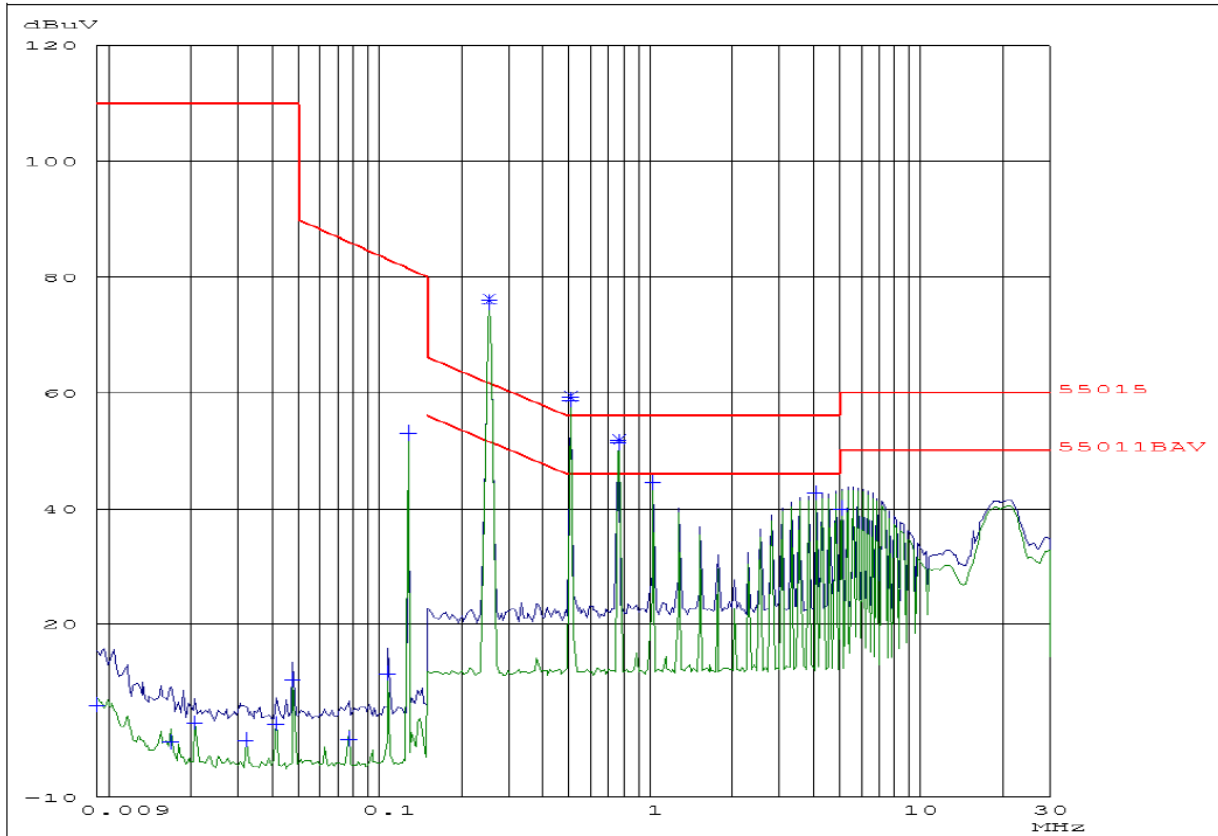

Figure 10: Example for a spectrum in interference voltage measurement (9 kHz – 30 MHz / Limit Class B).

APPLICATION NOTE

ANP032 | High Power Wireless Power Transfer for the Industrial Environment

The H field ($\frac{dI}{dt}$) can inductively couple interference currents into neighboring conduction paths. Usually a greater separation or a ferrite foil, such as [WE-FSFS](#), is helpful in combating this.

The E field ($\frac{dV}{dt}$) in particular capacitively couples very readily to earth. This can also be observed in the measurement of interference voltage as well as in the interference field strength. These common mode interference sources must be countered in the low frequency range (kHz) as well as in the higher frequency range (MHz).

As the E field (stray field) is the main cause of EMC problems in WPT applications, the appropriate measures have to be adopted:

- In order to reduce eddy currents, there should be slotted metal plane (e.g. PCB with copper) under the WPT coil (especially transmitter) and oriented towards the circuit. The circuit has to be connected via a capacitor (e.g. 1 - 100 nF / 2000 V [WCAP-CSMH](#)) to the circuit ground or case. This short-circuits a large proportion of the E field to the source and it no longer propagates via earth.
- Shield the transmitter and receiver coils and their drives with sufficient metal shielding and/or absorber material ([WE-FAS](#) / [WE-FSFS](#)).
- If the leakage currents allow, Y capacitors (2x4.7 nF max.) can reduce the interference levels over a broad spectrum ([WCAP-CSSA](#)).
- In order to filter common mode interference sources in the low frequency range (50 kHz – 5 MHz), depending on the operating voltage and current, the current-

compensated (common mode) chokes from the following series can be used:

[WE-CMB](#) / [WE-CMBNC](#) / [WE-UCF](#) / [WE-SL](#) / [WE-FC](#).

- In order to filter common mode interference sources in the higher frequency range (5 MHz – 100 MHz), depending on the operating voltage and current, the current-compensated chokes from the following series can be used:

[WE-CMB NiZn](#) / [WE-CMBNC](#) / [WE-SL5 HC](#) / [WE-SCC](#)

- Suppressing differential mode interference and depending on the operating voltage, capacitors from the following series can also be connected between +/- L/N:

[WCAP-FTXX](#) / [WCAP-CSGP](#).

- As very high AC currents flow in the entire circuit, depending on the application, a compact and low inductance PCB layout is essential for success in EMC. The components of the power stage and the resonant circuit should be placed very close to each other and connected with low inductance using large copper areas (polygons).

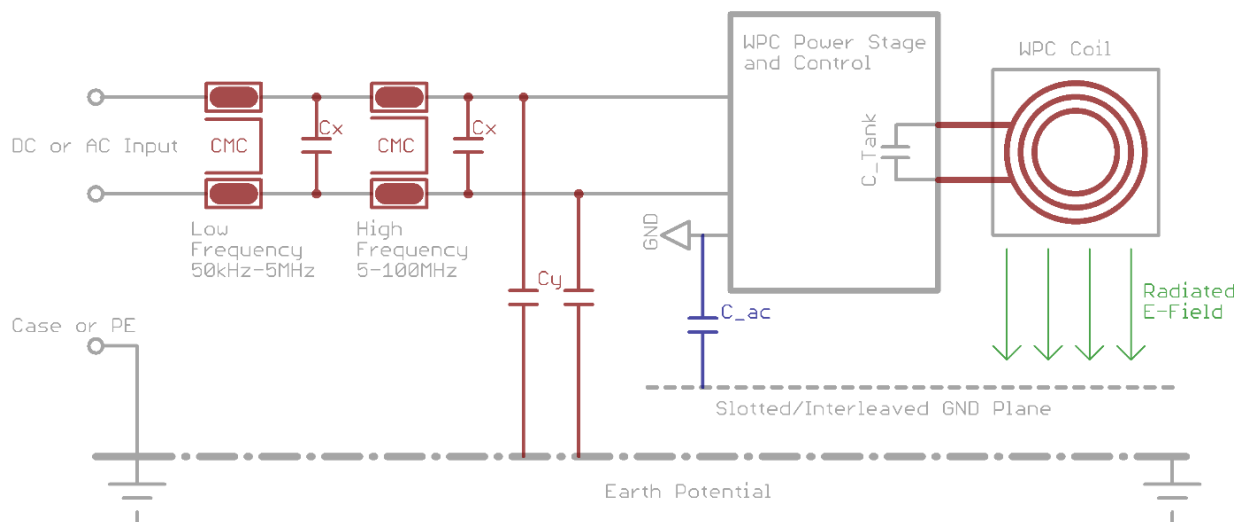

Figure 11: Measures for containment of common mode and differential mode interference sources.

APPLICATION NOTE

ANP032 | High Power Wireless Power Transfer for the Industrial Environment

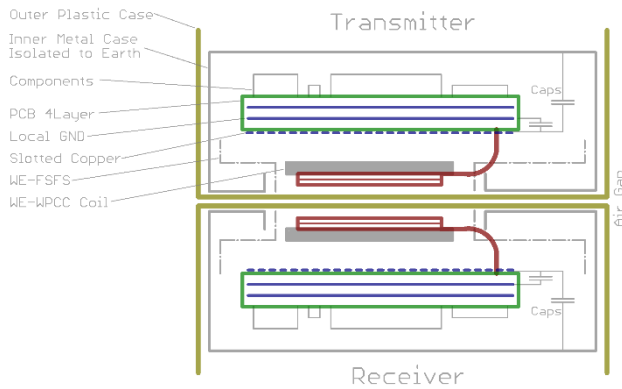

Figure 12: Example of a set-up where no Y capacitor to earth can be used due to the maximum permissible leakage currents (e.g. medical devices, hand-held devices, ATEX).

Generally it is recommended to work with a competent EMC lab during development to measure performance throughout the design process. Changes in mass production are always associated with higher expenses and additional workload.

2.2.2 Transmitter and Receiver Coils

In order to find the suitable wireless power transfer coil, some aspects should be considered first:

- How high is the maximum current anticipated (reactive and rated current) in the coil?
- What is the maximum permissible package size (L/W/H)?

In order to avoid unwanted saturation or over-temperature of the coils, a safety buffer of 30% should always be planned for. If several coils can be incorporated, those with the highest inductance should be used, as the resonant circuit capacitor can then be smaller. Additionally, this measure reduces the reactive currents occurring in the "tank". Smaller currents in the resonant circuit lead to lower self-heating and to better EMC properties.

Maximum current in the „tank“:

$$I_{\max} = U_{\text{in}} \cdot \pi \cdot \sqrt{\frac{C}{L}} \quad (6)$$

The best coupling is achieved when the transmitter and receiver coils have the same package size hence, a size ratio of 1:1 is recommended. The components from the **WE-WPCC family** (e.g. **760 308 102 142** (53 mmx53 mm), **760 308 100 143** (ø 50 mm), **760 308 100 110** (ø 50 mm)), were specially developed for high power. These coils can be used as transmitters and receivers. They are characterized by

very low R_{DC} values, very high Q values and very high saturation currents I_R .

2.2.3 Parallel Capacitor

Because high currents circulate in the parallel resonant circuit, not every capacitor technology is suitable for this task. Depending on the application, only three different types are available for selection: MKP (e.g. **WCAP-FTXX**, **WE-FTBP**), NPO (e.g. **WE-CSGP**) or FKP. On account of their low loss factor, these capacitor types are capable of sustaining high AC currents without overheating. However, depending on the power of the resonant converter, it is not uncommon to switch several capacitors in parallel to divide the currents and the self-heating. Care should be taken that none of the capacitors become warmer than 85 °C. As a result of their higher loss factors (especially dielectric losses), X7R, X5R, MKS etc. are not suitable for resonant converters. In consideration of the package size, costs and the lowest possible reactive current in the resonant circuit, the capacitance should be chosen to be as low as possible. Here the limiting factors are the converter's maximum working frequency, as well as the level of transmitter and receiver coil inductance. The voltage stability should be at least $\pi \cdot V_{\text{in}}$, plus an additional 20% safety reserve. It also has to be considered that the maximum permissible $V_{\text{AC-rms}}$ voltage for MKP capacitors drops markedly at frequencies below 5 kHz.

Capacitor loss factor in %:

$$DF = 2 \cdot \pi \cdot f \cdot \text{ESR}_{\text{cap}} \cdot C \cdot 100 \quad (7)$$

2.2.4 Filter Inductors

The two filter inductors moderately decouple the "AC" resonant circuit from the supply. At the same time, they also serve as a constant current source and filter element. The current carrying capacity has to be adapted to the maximum rated current of the circuit. A classical power inductor (e.g. **WE-HCI**; **WE-PD**; **WE-LHMI**) with air gap and high Q factor always has to be used. Its rated inductance should be at least 5 times higher than the inductance of the WPT coil in order to be in a position to reload sufficient energy into the resonant circuit. If the input/output ripple is still too high, the values of the filter inductor or capacitor can be increased. Alternatively, the filter components' ESR can be reduced for the same effect on the ripple. Flat wire power inductors (**WE-HCF** / **WE-HCI**) are advantageous in keeping AC and DC losses as low as possible at high currents. Since these inductors have to constantly reload a high AC current to the resonant circuit,

APPLICATION NOTE

ANP032 | High Power Wireless Power Transfer for the Industrial Environment

considerable self-warming occurs due to the hysteresis and eddy current losses in the core material. The level of inductance required is directly related to the capacitance of the filter capacitor. Further information is in section 2.2.7.

Inductor Q factor:

$$Q_L = \frac{X_L}{R_{DC}} \quad (8)$$

2.2.5 MOSFETs

Suitable selection of the N-MOSFETs primarily depends on the level of the supply voltage. If this is just 5 V, for example, a logic level type has to be used for driving the gates reliably. As most power MOSFETs have a maximum gate voltage of +/-20 V, measures have to be taken to protect the gates in case of a supply voltage above 20 V_{DC}. This may be a Zener diode to ground or a capacitive voltage divider, which keeps the gate voltage in the optimal range. Care must also be taken that the voltage at the gate is not too low, otherwise a MOSFET in the resonant converter will get stuck in linear amplifier operation mode, causing the circuit to enter a latch-up state. This usually leads to overheating of one of the two MOSFETs. Furthermore, care must be taken to prevent voltage overshoots of a factor of pi greater than the supply voltage. For example, at 20 V_{CC}, the MOSFETs have to withstand a drain-source voltage of at least 63 V. In this case 100 V_{DS} types should be used. The efficiency of the circuit depends significantly on how high the "On" resistance (R_{dson}) and gate charge (total gate charge) of the MOSFETs are. A compromise has to be found here, as MOSFETs with low R_{dson} usually have a higher total gate charge.

Charging / discharging current MOSFET gate:

$$I_{gate} = C_{gate} \cdot \frac{\Delta V_{gate}}{\Delta t_{sw}} \quad (9)$$

Losses Drain / Source transition:

$$P_V = I_d^2 \cdot R_{ds,on} \quad (10)$$

2.2.6 Diodes and Pull-ups

As the MOSFETs have to be recharged relatively quickly, fast currents in the high Ampere range arise with the charge and discharge of the gate. These charging/discharging currents have to be routed via the pull-up resistors and the diodes. The losses arising are not negligible. For this reason, the maximum allowed power loss (P_V) and the current carrying

capacity of these components have to be chosen appropriately. Likewise, the diodes must have the same voltage stability as the MOSFETs. As an alternative to classical diodes or Schottkys, the body diodes of MOSFETs can also be used. Depending on the type, they can display beneficial properties at a high temperature, which are usually stated in the datasheet. The reverse recovery losses should also not be underestimated and have to be considered.

Loss power pull-up / diode:

$$P_V = (U_{diode} \cdot I) + (I^2 \cdot R_{pull-up}) \quad (11)$$

2.2.7 Input and Output Capacitor

These capacitors, in combination with the power inductors, serve mainly as filters. As the resonant frequencies are below 200 kHz, the capacitors have to be correspondingly higher. Tests have shown that values between 10 and 1000 µF are to be anticipated, depending on the application and power inductors used. The -6 dB cut-off frequency resulting from the LC filter should be around 1/10 of the resonant circuit frequency. In theory, attenuation of 40 dB / dec is expected. Taking parasitic component effects into consideration, 30 dB / dec should be expected in practice. Depending on the filter coil used, a significantly high AC current component can be superimposed on the DC current. If this current is too high, an aluminum polymer capacitor can be used in place of an aluminum electrolytic capacitor to withstand large AC currents. Polymer and ceramic capacitors, with their low ESR, also offer the possibility of significantly reducing the amplitude of the reflected voltage ripple. A smaller voltage ripple means that there is a lower interference level in the EMC interference measurement. The best result is obtained by using a parallel connection of aluminum electrolyte capacitors and polymer or ceramic capacitors (e.g. [WCAP-PTHR](#) / [WCAP-PSLC](#)).

Cut-off frequency input/output filter:

$$f_{-6dB} = \frac{1}{2 \cdot \pi \cdot \sqrt{L \cdot C}} \quad (12)$$

Voltage drop across capacitor:

$$U_{ripple} = ESR \cdot I_{AC} \quad (13)$$

APPLICATION NOTE

ANP032 | High Power Wireless Power Transfer for the Industrial Environment

APPLICATION NOTE

ANP032 | High Power Wireless Power Transfer for the Industrial Environment

2.3 Pitfalls with the Resonant Converter

Two things in particular have to be considered in practice with this circuit topology to prevent latch-up of the MOSFETs.

1. The power supply of the transmitter at the moment of switching

If the power supply is not in a position to deliver sufficient current during transient oscillation of the circuit, it may occur that one of the two MOSFETs gets stuck in linear amplification mode and the input voltage permanently shorted to ground. This would cause the MOSFET to overheat and suffer permanent damage. Attention should also be paid that the input filter capacitor is not over-dimensioned, which could possibly further exacerbate this "latch up" effect, as the power supply has more capacitance to charge.

This effect can be avoided in practice by connecting the capacitors and the resonant circuit to the operating voltage before the rest of the circuit. The gates of the MOSFETs can then be switched via optocouplers or transistors. The gates can also be driven via a separate voltage source (e.g. [Würth Elektronik Magi³C Power Module](#)) whose switching is delayed from the supply.

2. The impedance reflected from the receiver side to the transmitter side

Given large load jumps on the receiver side or sudden changes in the coupling factors of the two coils, it may occur that the reflected impedance partially short-circuits the magnetizing inductance of the transmitter side. This, in turn, can lead to the oscillation breaking down and the circuit going into a "latch-up" state.

Coupling factor:

$$k = \frac{U_{\text{sec}}}{U_{\text{pri}} \cdot \pi} \cdot \frac{N_{\text{pri}}}{N_{\text{sec}}} = \frac{M}{\sqrt{L_{\text{pri}} \cdot L_{\text{sec}}}} \quad (14)$$

Mutual inductance:

$$M = k \sqrt{L_{\text{pri}} \cdot L_{\text{sec}}} \quad (15)$$

To counteract this, it is helpful to slightly detune the frequency of the receiver resonant circuit with the aid of another parallel capacitor (10 - 20% higher frequency than the transmitter). Alternatively, an additional inductance (power inductor) can be connected in parallel to the transmitter coil, which has no magnetic coupling with the transmission path. This parallel inductance has to be equal to or less than the magnetization inductance of the transmitter coil. This parallel inductance stores energy during the ZVS process and helps to maintain the oscillation in the event of unfavorable load transients.

Reflected impedance with parallel compensation:

$$Z_{\text{re}} = \frac{(2 \cdot \pi \cdot f)^2 \cdot M^2}{L_{\text{sec}}} \cdot \left(\frac{R_{\text{load}}}{(2 \cdot \pi \cdot f \cdot L_{\text{sec}})} - j \right) \quad (16)$$

Resonance capacitor receiver:

$$C_{\text{sec}} = \frac{1}{L_{\text{sec}} \cdot \sqrt{1 - k^2} \cdot (2 \cdot \pi \cdot f)^2} \quad (17)$$

Additional compensation capacitance receiver:

$$C_{\text{comp}} = \frac{1}{(2 \cdot \pi \cdot f)^2 \cdot L_{\text{pri}} \cdot \sqrt{1 - k^2}} \quad (18)$$

In the first prototype phase it is important to test out all conceivable load situations, as far as this is possible, to ensure a robust design with proper functionality.

APPLICATION NOTE

ANP032 | High Power Wireless Power Transfer for the Industrial Environment

2.4 Optimization of the WPT Coil Environment

If the WPT coils are secured on metal, there may be inductive losses due to induced eddy currents caused by the magnetic stray field. In addition, the metal close by (e.g. copper on PCBs) may heat up inadvertently. Electronic circuits can also be inadvertently influenced by the strong magnetic stray fields. This effect will be higher with increased separation of the WPT coils.

Suitable measures include increasing the separation of the coils to the PCB/metal, as well as the use of highly permeable ferrite foil, such as **WE-FSFS**. Thus, the magnetic flux is specifically directed and is not converted into heat. This also allows the coupling factor, and therefore the efficiency, to be raised. These self-adhesive and flexible ferrite foils are available in several sizes and thicknesses.



Permeability vs. Frequency:

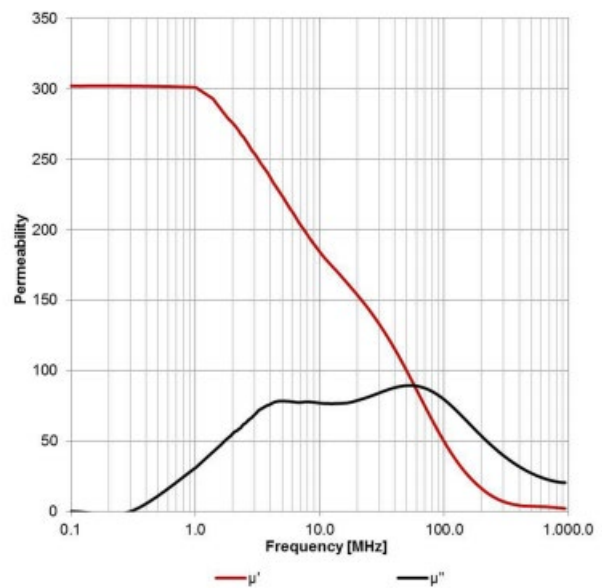

Figure 13: WE-FSFS Art. No. [374 006](#) (μ' is the real part and μ'' the imaginary part / losses).

3. APPLICATION EXAMPLES

3.1 Simple Receiver Circuit

TVS Power Diode to protect against transient over-voltages (bidirectional; max. operating voltage 60 V).

Please note: Observe precautionary measures and touch protection with voltages above 50 V_{AC} / 120 V_{DC}!

APPLICATION NOTE

ANP032 | High Power Wireless Power Transfer for the Industrial Environment

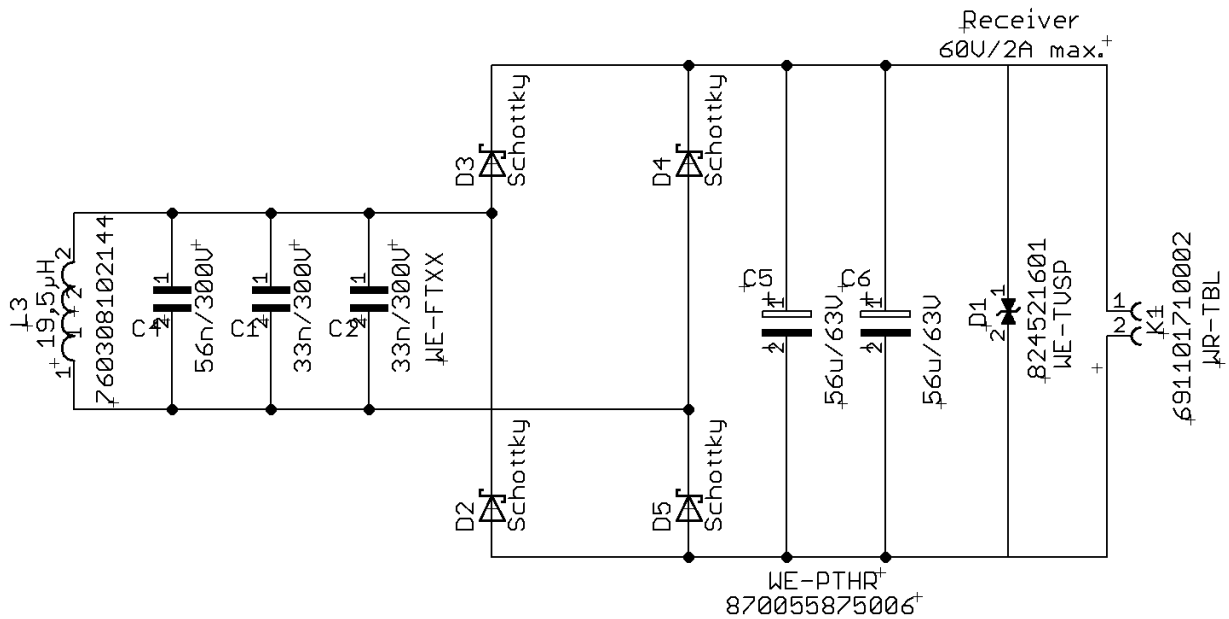

Figure 14: Bridge rectifier circuit with Schottky diodes and ripple current resistant aluminum polymer SMD capacitors. Output power of this receiver circuit is approx. 20 W depending on the cooling surface.

3.2 Standard Resonant Converter (Transmitter and Receiver up to approx. 10 W)

Please note: Observe precautionary measures and touch protection with voltages above 50 V_{AC} / 120 V_{DC}!

APPLICATION NOTE

ANP032 | High Power Wireless Power Transfer for the Industrial Environment

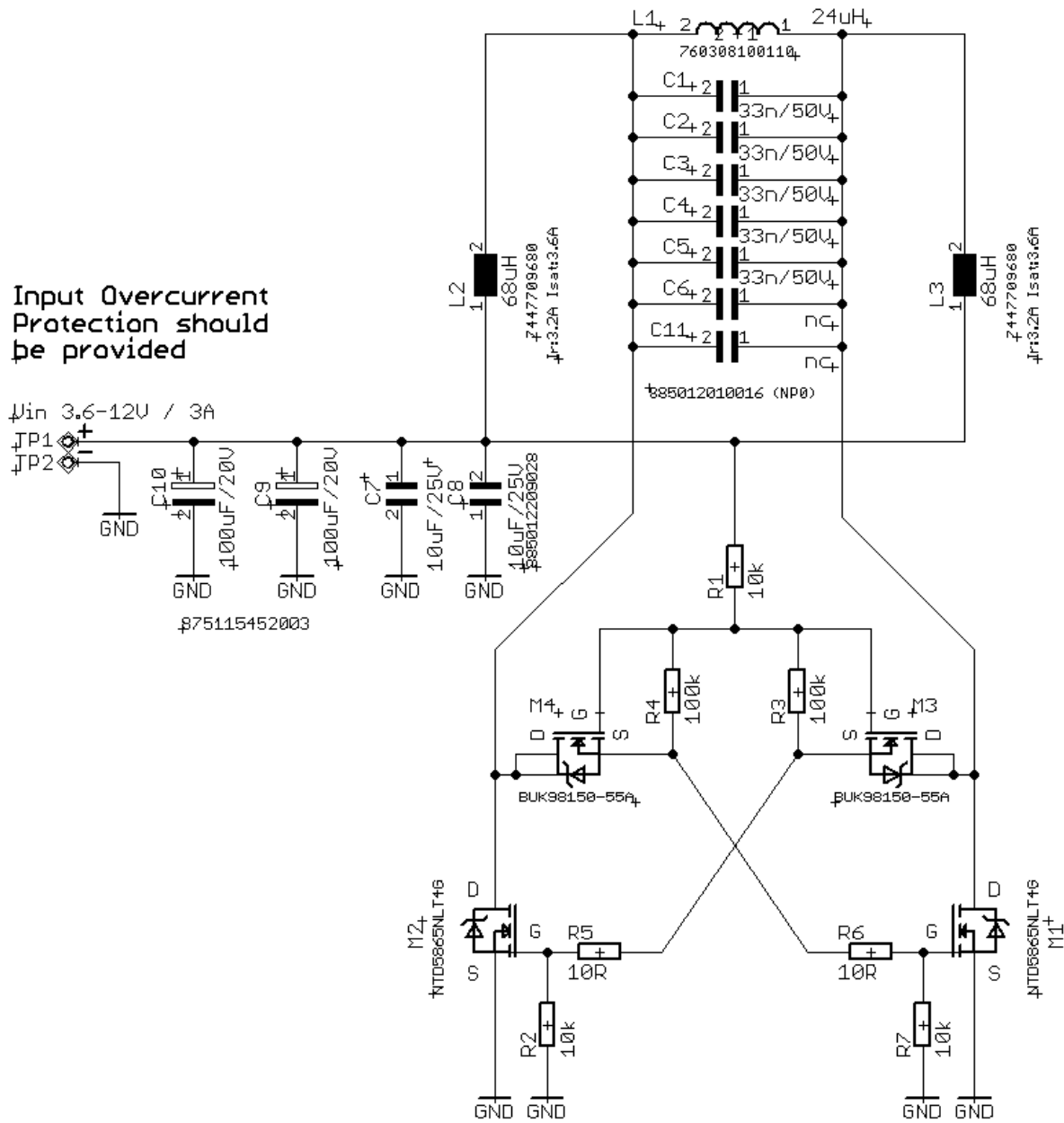

Figure 15: Example of simple transmitter/receiver resonator circuitry for use up to 10 W. An input current monitoring should be implemented for all transmitters. This protects the power FETs from thermal overload. If the oscillation does not start properly or breaks down during operation, one of the power FETs would be permanently controlled by GND and thus thermally destroyed. Logic level FETs must be used for supply voltages below 9 V.

APPLICATION NOTE

ANP032 | High Power Wireless Power Transfer for the Industrial Environment

3.3 Example of a Modified Receiver Circuit (up to approx. 50 W)

Please note: Observe precautionary measures and touch protection with voltages above 50 V_{AC} / 120 V_{DC}!

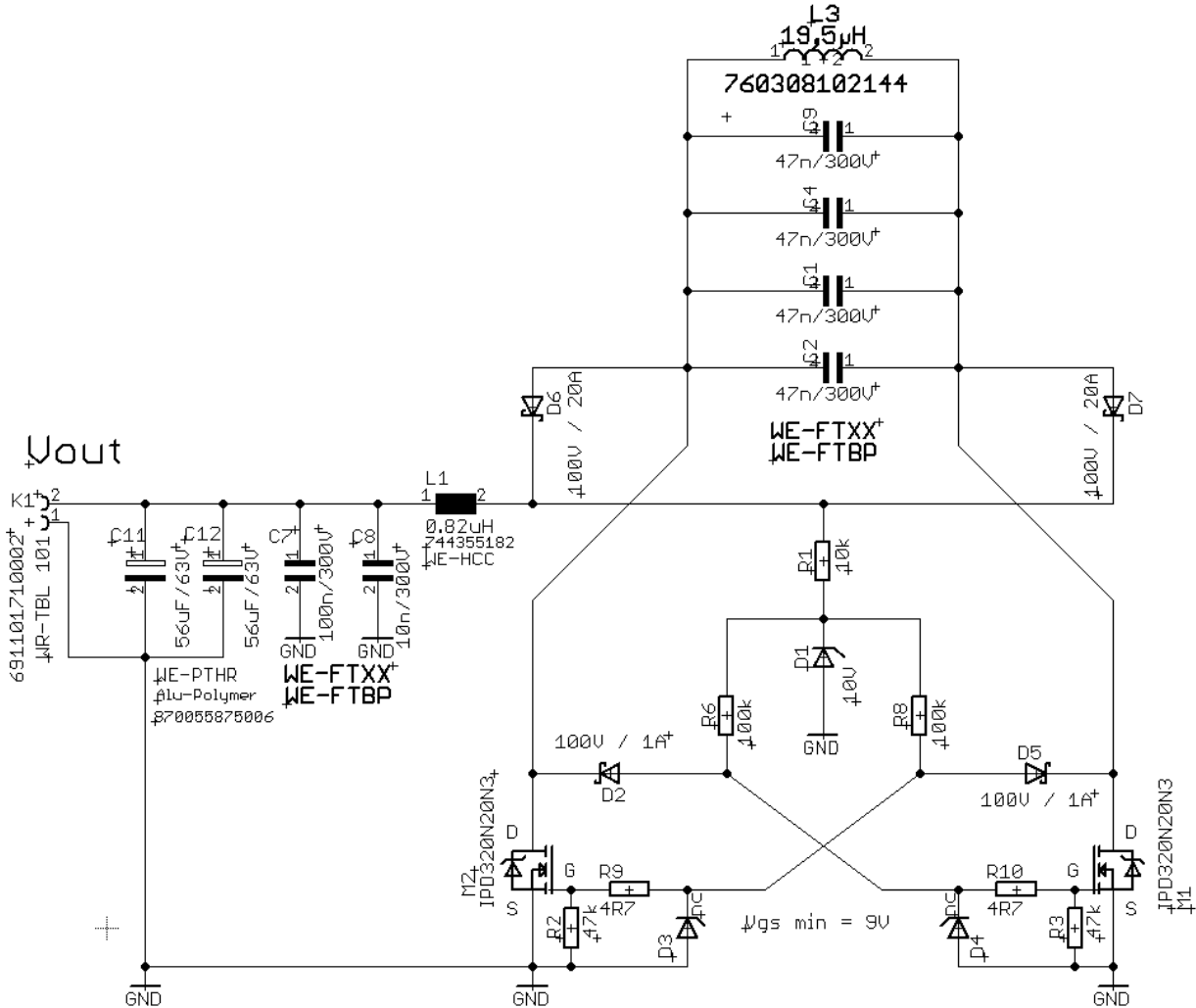

Figure 16: Replacing the filter inductors with power Schottky diodes allows higher output voltages by double rectification at the receiver; output filter (C7 / C8 / L1) required; to feed the gates, a small voltage can be generated from the high DC voltage at L1 with the help of an LDO/buck converter, whereby the voltage dividers and ten diodes can be removed from the design. This circuit can only be used on the receiver side for up to 50 W. If no logic level FETs are used, at least 9 V gate source voltage is required for a safe and reliable transmission.

APPLICATION NOTE

ANP032 | High Power Wireless Power Transfer for the Industrial Environment

3.4 Example of Push-Pull Gate Control (Transmitter and Receiver up to approx. 100 W)

Please note: Observe precautionary measures and touch protection with voltages above 50 V_{AC} / 120 V_{DC}!

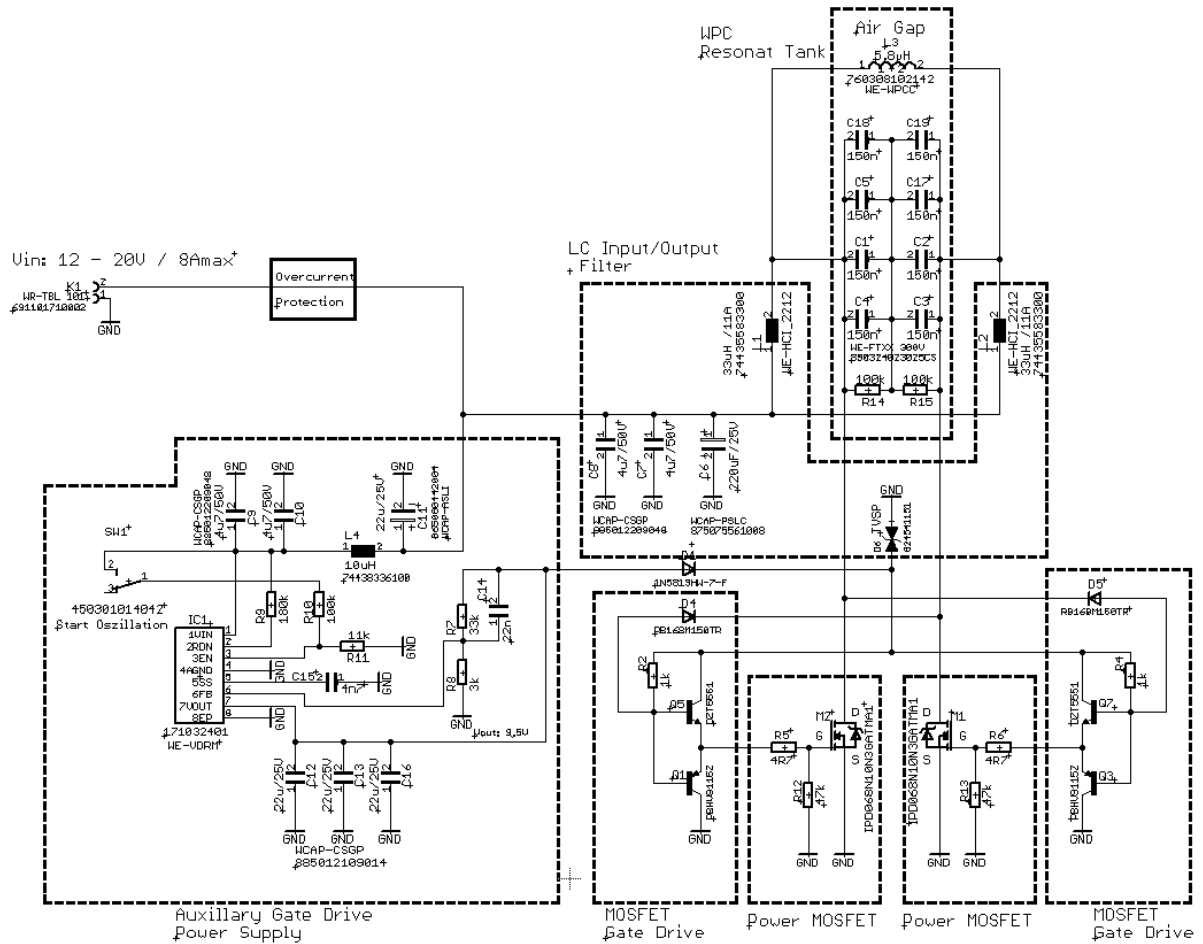

Figure 17: Control of the power MOSFET gates via push-pull switching of the gates instead of half sine; this circuit can be used on the transmitter and receiver side. The 8 – 10 V auxiliary voltage can be generated from the operating voltage by means of an LDO or WE Power Module (171 012 401). An overcurrent cut-off at the input should always be used. If the oscillation does not start properly or breaks down during operation, one of the power FETs will be permanently connected to GND and thus thermally destroyed. Logic level FETs must be used for supply voltages below 9 V.

APPLICATION NOTE

ANP032 | High Power Wireless Power Transfer for the Industrial Environment

3.5 Example of Push-Pull Gate Control (Transmitter and Receiver up to approx. 60 W)

Please note: Observe precautionary measures and touch protection with voltages above 50 V_{AC} / 120 V_{DC}!

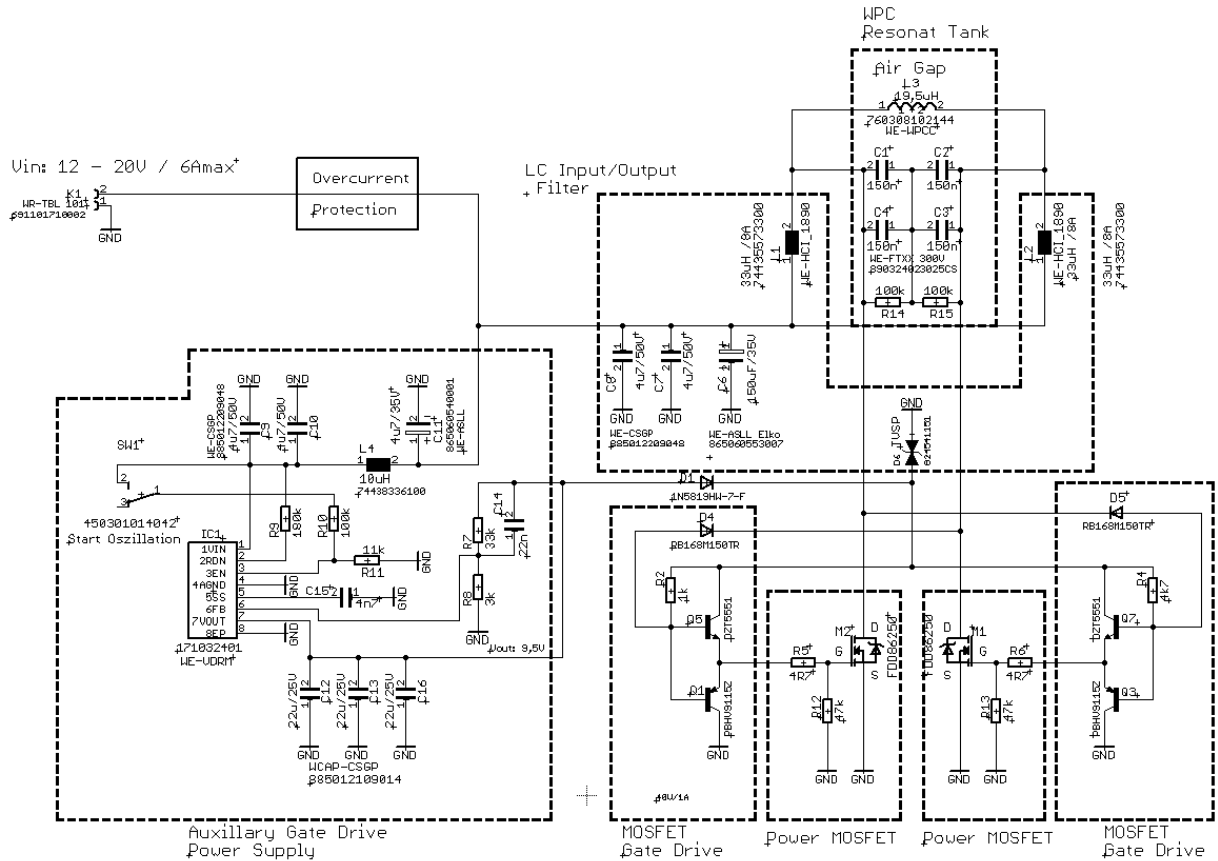

Figure 18: Control of the power MOSFET gates via push-pull switching of the gates instead of half sine; this circuit can be used on the transmitter and receiver side. The 8 – 10 V auxiliary voltage can be generated from the operating voltage by means of an LDO or WE Power Module (171 012 401). An overcurrent cut-off at the input should always be used. If the oscillation does not start properly or breaks down during operation, one of the power FETs would be permanently connected to GND and thus thermally destroyed. Logic level FETs must be used for supply voltages below 9 V.

APPLICATION NOTE

ANP032 | High Power Wireless Power Transfer for the Industrial Environment

3.6 Example of Push-Pull Gate Control (Transmitter and Receiver up to approx. 30 W)

Please note: Observe precautionary measures and touch protection with voltages above 50 V_{AC} / 120 V_{DC}!

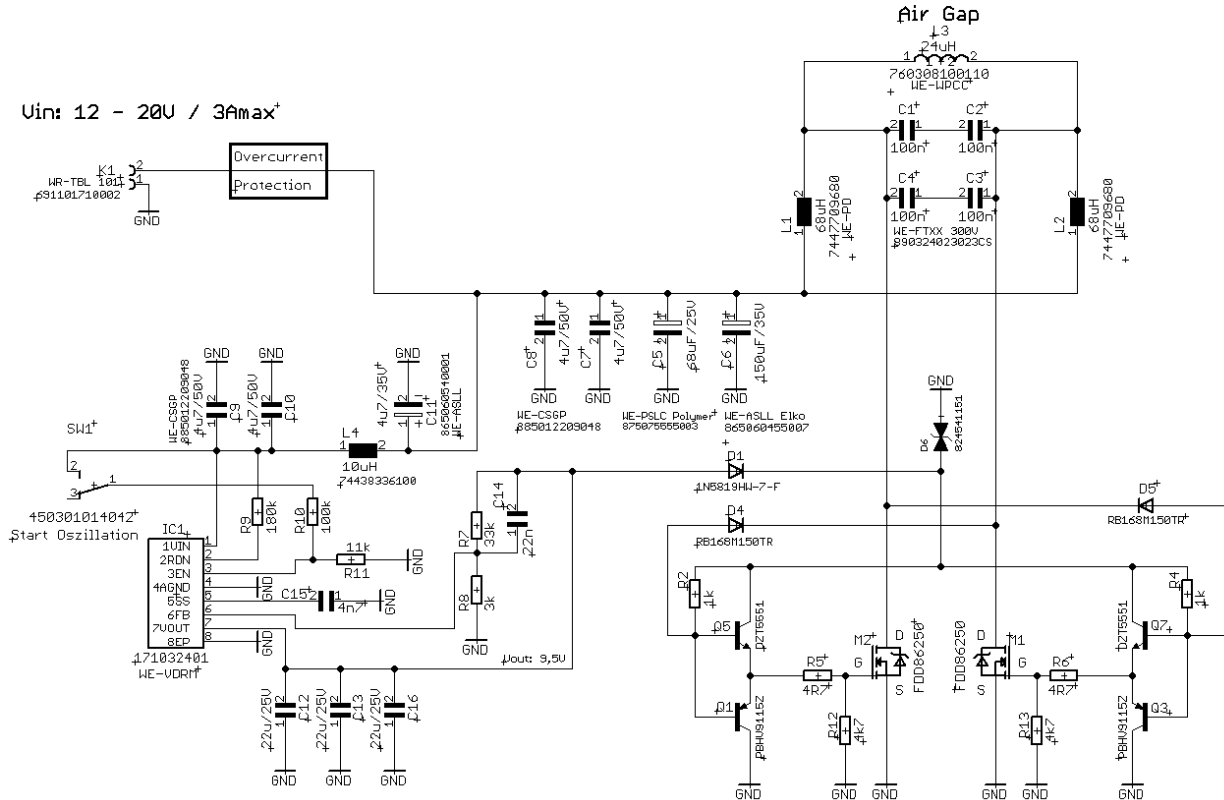

Figure 19: Control of the power MOSFET gates via push-pull switching of the gates instead of half sine; this circuit can be used on the transmitter and receiver side. The 8 – 10 V auxiliary voltage can be generated from the operating voltage by means of an LDO or WE Power Module (171 012 401). An overcurrent cut-off at the input should always be used. If the oscillation does not start properly or breaks down during operation, one of the power FETs would be permanently connected to GND and thus thermally destroyed. Logic level FETs must be used for supply voltages below 9 V.

APPLICATION NOTE

ANP032 | High Power Wireless Power Transfer for the Industrial Environment

3.7 Application of a Double Resonant Converter (up to 20 V / 8 A max.)

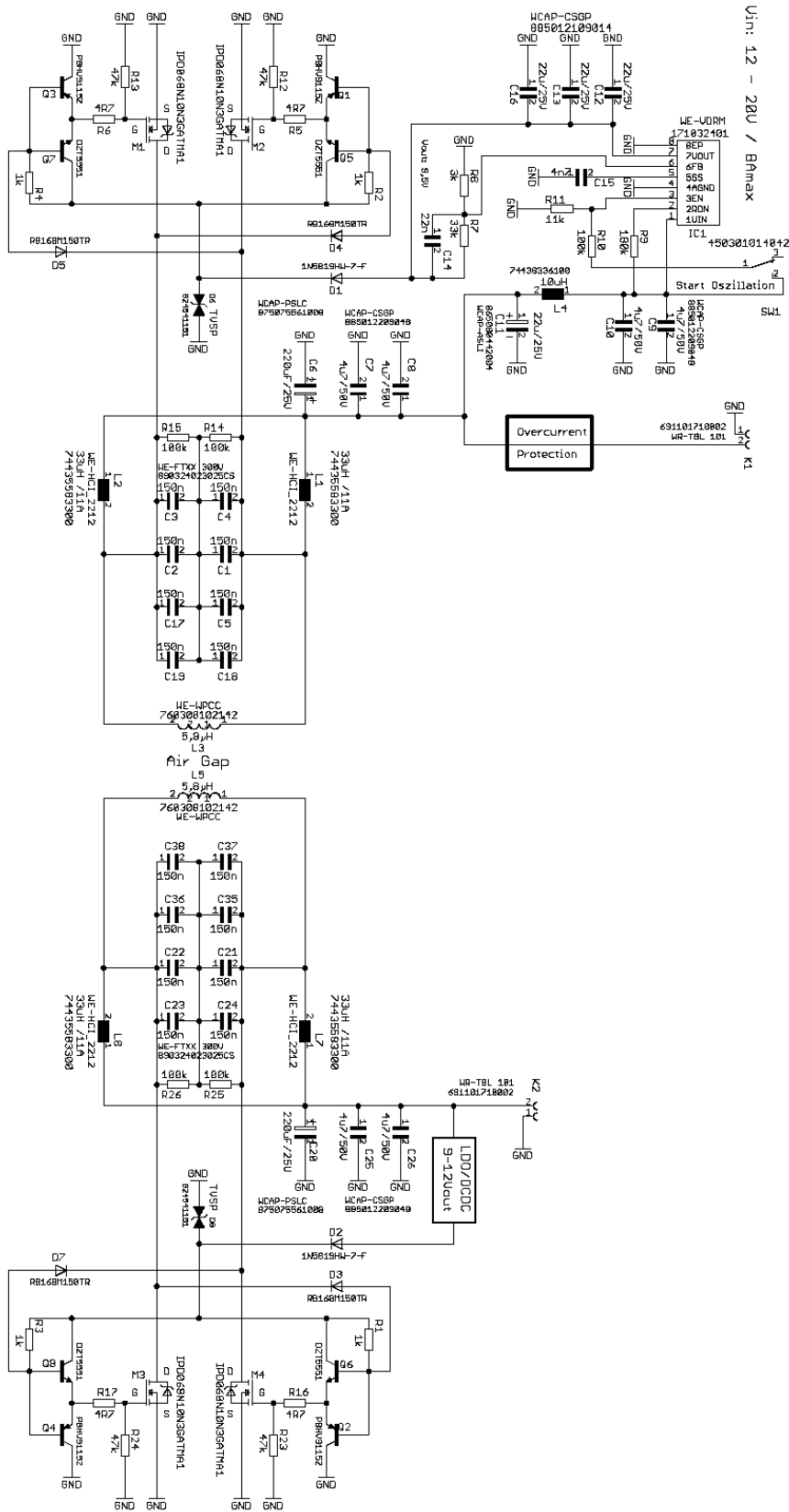

Figure 20: Transmitter and receiver for approx. 100 W.

APPLICATION NOTE

ANP032 | High Power Wireless Power Transfer for the Industrial Environment

3.8 Application of a Resonant Converter with Center Tap (up to 30 W)

Please note: Observe precautionary measures and touch protection with voltages above 50 V_{AC} / 120 V_{DC}!

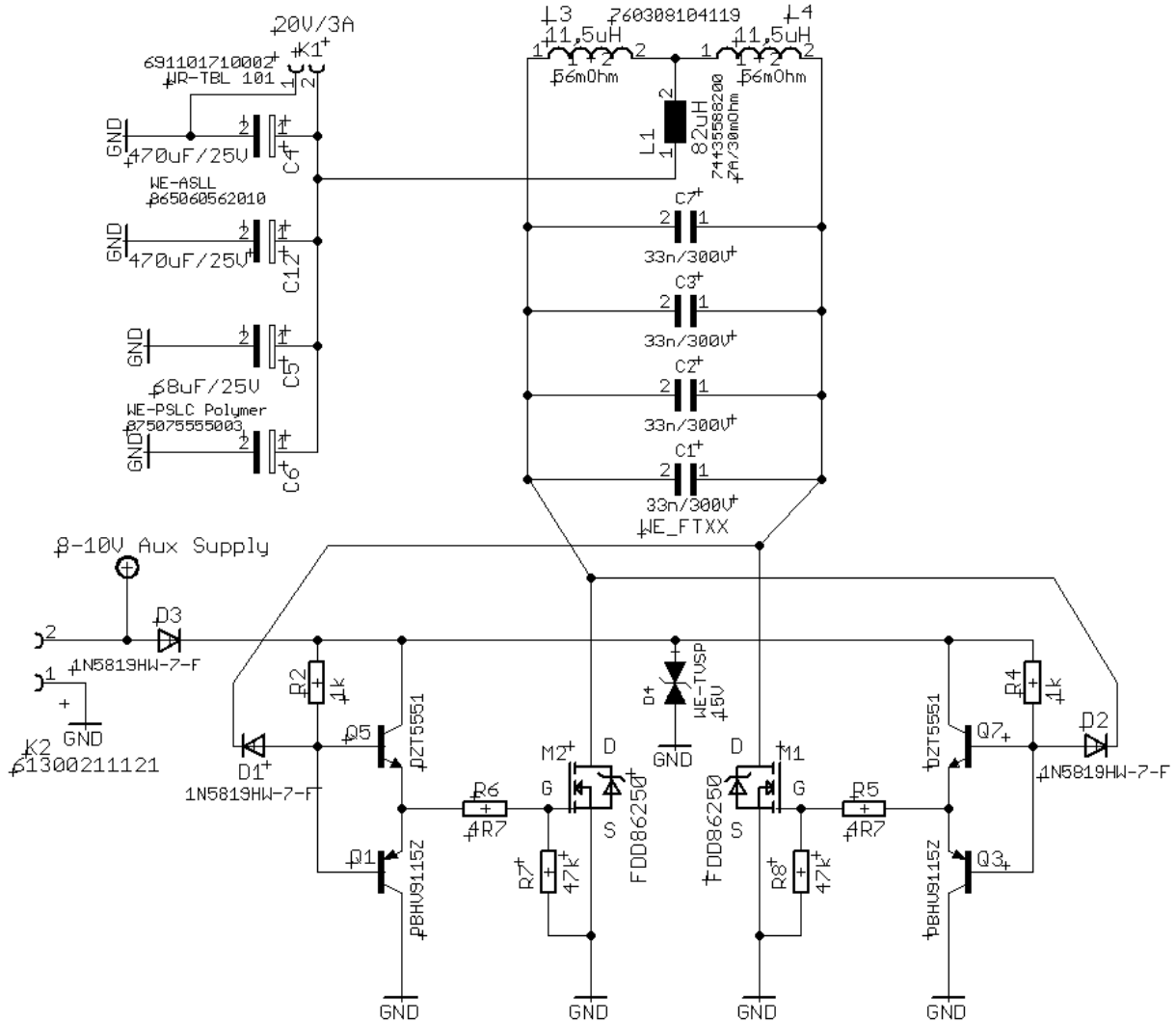

Figure 21: Resonanzwandler für Spulen mit Mittelabgriff. Der Vorteil der Schaltung liegt darin, dass man nur eine Filterspule benötigt. Durch die Mittelanzapfung ist die Frequenz doppelt so hoch und der Spannungshub kleiner. Dadurch können kleinere Filterspulen verwendet werden. Zudem lässt sich so auch ein Array mit zwei sich überlappenden Spulen einfach ansteuern. Die 8 - 10 V Hilfsspannung kann man mit Hilfe eines LDO oder WE Magic Power Modul (171.012.401) aus der Betriebsspannung erzeugen.

APPLICATION NOTE

ANP032 | High Power Wireless Power Transfer for the Industrial Environment

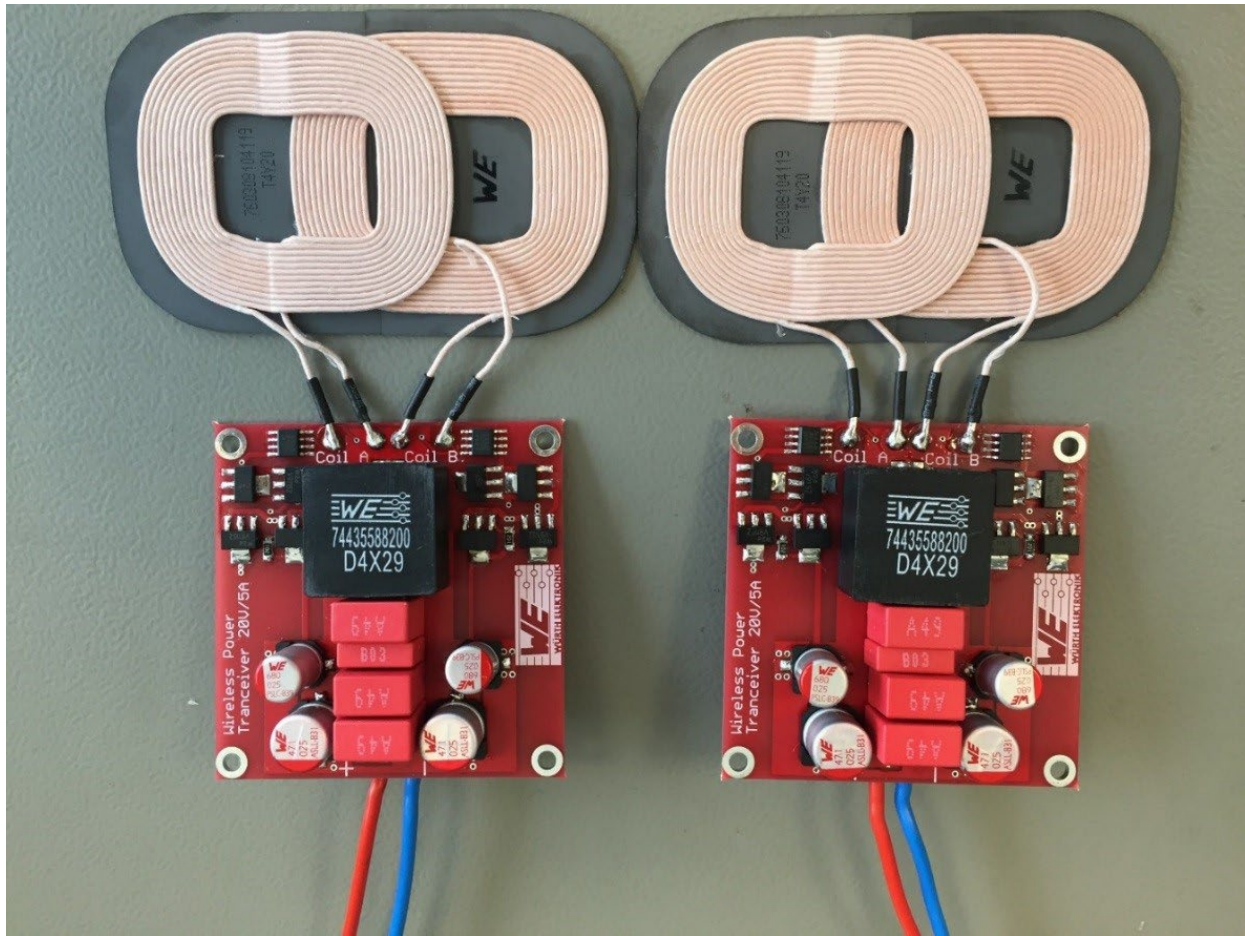

Figure 22: Construction for application example transmitter/receiver 3.9 for coil array (760 308 104 119).

4. SUMMARY

This resonant converter is very flexible and can be adapted to the requirements of many different applications this circuit currently represents the most effective wireless transfer of energy of up to several hundred Watts. If the demands of the application grows in terms of safety, On/Off, charging state detection etc., this circuit can serve as the basis and be extended by the hardware developer. A classical H bridge circuit with active regulation can also be taken as the basis rather than the resonant converter topology. In any case, EMC measurements should be performed on the first prototypes

at an early stage during development. High efficiency, the most compact package and good EMC properties essentially depend on the clocking circuit, as well as the transmitter and receiver coils. Besides the widest product range, Würth Elektronik also offers coils with the highest Q factors in their respective packages. This allows higher inductance values to be attained and results in smaller packages for the capacitors.

In addition, HF litz (stranded) wire is used exclusively for high power (lower AC losses) with high quality ferrite material (high permeability). This means the maximum efficiency and best possible EMC performance for the end product.

5. BOM FOR APPLICATION EXAMPLE OF DIGIKEY

| Description | Package type | Value | Part number |
|---|---------------------------------|--|--|
| WE-WPCC Transmitter and receiver coils | 53x53 mm 50 mm \varnothing | L=5,8 μ H I _R =18 A I _{SAT} =30 A L=6,0 μ H I _R =12 A I _{SAT} =24 A | 760 308 102 142 760 308 100 143 |
| WCAP-FTXX Resonance capacitor | Pitch 10 mm | C=100 nF / 310 V DF=0.1% | 890 334 023 023 CS |
| WE-HCI Filter coil | 2212 | L=33 μ H I _R =11.5 A I _{SAT} =15 A | 744 355 833 00 |
| Power MOSFET | DPAK | V _{DS} =150 V I _D =8 A | FDD86250 |

APPLICATION NOTE

ANP032 | High Power Wireless Power Transfer for the Industrial Environment

| | | | |
|--|------------|--|--|
| | | $R_{DS,on} = 22 \text{ m}\Omega$ | |
| WCAP-PSLC // WCAP-ASLL Filter capacitor | V-Chip SMD | C=68 μF / 25 V // C=470 μF / 25 V | 875 075 555 003 865 060 457 009 |
| Universal MOSFET | MSOP8 | Vds:150 V Id: 3.5 A Rdson: 85 mOhm | SI4848DY |
| Gate series resistor | 1206 | 4.7 – 10 Ohm 0.5 W | |
| WE-TBL Terminal block | 5 mm pitch | WR-TBL 101 (10 A max.) | 691 102 710 002 |
| Pull-up resistors | 1206 | 10 k – 100 kOhm | |

APPLICATION NOTE

ANP032 | High Power Wireless Power Transfer for the Industrial Environment

IMPORTANT NOTICE

The Application Note is based on our knowledge and experience of typical requirements concerning these areas. It serves as general guidance and should not be construed as a commitment for the suitability for customer applications by Würth Elektronik eiSos GmbH & Co. KG. The information in the Application Note is subject to change without notice. This document and parts thereof must not be reproduced or copied without written permission, and contents thereof must not be imparted to a third party nor be used for any unauthorized purpose.

Würth Elektronik eiSos GmbH & Co. KG and its subsidiaries and affiliates (WE) are not liable for application assistance of any kind. Customers may use WE's assistance and product recommendations for their applications and design. The responsibility for the applicability and use of WE Products in a particular customer design is always solely within the authority of the customer. Due to this fact it is up to the customer to evaluate and investigate, where appropriate, and decide whether the device with the specific product characteristics described in the product specification is valid and suitable for the respective customer application or not.

The technical specifications are stated in the current data sheet of the products. Therefore the customers shall use the data sheets and are cautioned to verify that data sheets are current. The current data sheets can be downloaded at www.we-online.com. Customers shall strictly observe any product-specific notes, cautions and warnings. WE reserves the right to make corrections, modifications, enhancements, improvements, and other changes to its products and services.

WE DOES NOT WARRANT OR REPRESENT THAT ANY LICENSE,

EITHER EXPRESS OR IMPLIED, IS GRANTED UNDER ANY PATENT RIGHT, COPYRIGHT, MASK WORK RIGHT, OR OTHER INTELLECTUAL PROPERTY RIGHT RELATING TO ANY COMBINATION, MACHINE, OR PROCESS IN WHICH WE PRODUCTS OR SERVICES ARE USED. INFORMATION PUBLISHED BY WE REGARDING THIRD-PARTY PRODUCTS OR SERVICES DOES NOT CONSTITUTE A LICENSE FROM WE TO USE SUCH PRODUCTS OR SERVICES OR A WARRANTY OR ENDORSEMENT THEREOF.

WE products are not authorized for use in safety-critical applications, or where a failure of the product is reasonably expected to cause severe personal injury or death. Moreover, WE products are neither designed nor intended for use in areas such as military, aerospace, aviation, nuclear control, submarine, transportation (automotive control, train control, ship control), transportation signal, disaster prevention, medical, public information network etc. Customers shall inform WE about the intent of such usage before design-in stage. In certain customer applications requiring a very high level of safety and in which the malfunction or failure of an electronic component could endanger human life or health, customers must ensure that they have all necessary expertise in the safety and regulatory ramifications of their applications. Customers acknowledge and agree that they are solely responsible for all legal, regulatory and safety-related requirements concerning their products and any use of WE products in such safety-critical applications, notwithstanding any applications-related information or support that may be provided by WE.

CUSTOMERS SHALL INDEMNIFY WE AGAINST ANY DAMAGES ARISING OUT OF THE USE OF WE PRODUCTS IN SUCH SAFETY-CRITICAL APPLICATION.

USEFUL LINKS



Application Notes

www.we-online.com/apnotes



REDEXPERT Design Platform

www.we-online.com/redexpert



Toolbox

www.we-online.com/toolbox



Product Catalog

www.we-online.com/products

CONTACT INFORMATION



apnotes@we-online.com

Tel. +49 7942 945 - 0



Würth Elektronik eiSos GmbH & Co. KG

Max-Eyth-Str. 1 74638 Waldenburg Germany

www.we-online.com